



We have reached another GPS milestone. Just a few months ago, GPS World celebrated its 10th anniversary. The first issue of the magazine (a bimonthly in its first year of publication) appeared in January/February 1990. The "Innovation" column has appeared in every regular issue of GPS World, and this month's column is number 100.

Throughout the column's 10-year history, we have examined many innovative developments in the GPS world, including improvements in precise positioning, velocity determination, and the transfer of time; in applications such as real-time dredge positioning, monitoring the deformation of the Earth's crust, the Earth's rotation, and the state of its ionosphere; and the use of GPS on various platforms such as submersible vehicles, aircraft, and satellites.

Many of these developments were possible because of advances in GPS receiver technology. The technology has resulted in GPS receivers becoming smaller and more convenient to use and recently permitted receivers so small that they can be incorporated into cellular telephones and other devices. On the occasion of the 100th "Innovation" column, what better time to review the progress of GPS receiver technology throughout the past 20 years and to take a peek into its future.

Smaller and Smaller: The Evolution of the GPS Receiver

Richard B. Langley University of New Brunswick

Just like Grant Williams in the classic science fiction film, *The Incredible Shrinking Man*, the GPS receiver keeps getting smaller and smaller. This trend is shared by portable electronic equipment of all kinds, fueled by consumer demand for products that are smaller, lighter, faster, and cheaper. Cellular telephones, pagers, and personal digital assistants, for example, all have become smaller during the past few years while the number of features they offer has increased.

The desire to embed GPS units in other products has driven the miniaturization trend in particular, with manufacturers continually striving to reduce the number of components needed to build a receiver. In fact, a basic GPS receiver can now be fabricated with just two or three major integrated circuits. The increasing use of digital technology in GPS receivers has aided these advances, allowing a reduction in power consumption and size. Manufacturers have been able to shrink receiver components to the point that one company recently put a "Dick Tracy"-style wristwatch GPS receiver on the market.

But size is not all that matters. We have witnessed many advances in GPS receiver technology during the past 20 years. At the high end, receivers for engineering and scientific applications have become more powerful with all-satellites-in-view tracking capabilities, low-noise measurements, and real-time-kinematic on-the-fly ambiguity resolution, to mention only a few currently available enhancements. At the low end, features can be traded for cost, with basic handheld receivers now offered for less than \$100. But receiver miniaturization is perhaps the most significant and far-reaching of all the developments.

To better understand this miniaturization trend, we shall examine in this article some of the technological advances that have reduced the size of a GPS receiver from two racks of equipment to that of a slightly bulky wristwatch. But first, let's briefly review the basic GPS receiver building blocks that are common to all units, regardless of size.

ESSENTIAL ELEMENTS

A GPS receiver consists of a number of basic components: an antenna with optional pream-

plifier, a radio-frequency and intermediate-frequency (RF/IF) "front end" section, a signal tracker/correlator section, and a microprocessor that controls the receiver, processes the signals, and computes the receiver's coordinates. The receiver will also include a power supply and memory devices for storing instructions and data.

Antenna. The antenna's job is to convert the energy in the electromagnetic waves arriving from the satellites into an electrical current that can be handled by the electronics in the receiver. The antenna's size and shape are very important, as these characteristics govern, in part, the antenna's ability to pick up and pass on to the receiver the very weak GPS signals. Typical antennas for GPS use include microstrip patches and quadrifilar helices. An *active* antenna is one that, besides the antenna element, includes a low-noise preamplifier (with one or more associated filters) to boost the weak signals. This type of unit is used if the antenna and receiver are separated by some distance.

A Front End. A GPS receiver's RF/IF section serves to translate the frequency of the signals arriving at the antenna to a lower frequency, called an intermediate frequency or IF, which is more easily managed by the rest of the receiver. A receiver component known as a local oscillator performs this task by combining the incoming RF signal with a pure sinusoidal signal or tone. Most GPS units use precision quartz crystal oscillators, enhanced versions of the regulators commonly found in wristwatches. Some geodetic-quality devices provide for the option of obtaining the local oscillator signal from an external source such as an atomic frequency standard (rubidium vapor, cesium beam, or hydrogen maser), which has a higher frequency stability. Receivers supplied with such a signal can produce carrier-phase measurements with less clock noise.

The IF signal contains all of the modulation that is present in the transmitted signal; only the carrier has been shifted in frequency. The shifted carrier's frequency is simply the difference between the original received carrier frequency and that of the local oscillator. It is often called a beat frequency in analogy to

the beat note heard when two musical tones very close together are played simultaneously. Some receivers employ multiple IF stages, reducing the carrier frequency in steps. Filters are used at each IF stage to suppress out-of-band interference and other undesired signals. The final IF signal passes to the signal trackers or correlators.

Correlators. The omnidirectional antenna of a GPS receiver simultaneously intercepts signals from all satellites above the antenna's horizon. The receiver must be able to isolate the signals from each particular satellite to measure the code pseudorange and the phase of the carrier. Isolation is achieved by using a number of channels and assigning each signal to a particular channel. This is not difficult to accomplish, because the unique C/A-code or portion of the P-code transmitted by each satellite enables easy discrimination of the different signals.

Until the early 1990s, receivers with single channels were cheaper to build than multichannel units.

The channels in a GPS receiver may be implemented in one of two basic ways. A receiver may have dedicated channels that continuously track particular satellites. A minimum of four such channels tracking the L1 signals of four satellites with good geometry would be required to determine three coordinates of position and the receiver clock offset. Additional channels permit tracking of more satellites including, perhaps, GLONASS or SBAS (satellite-based augmentation system) satellites, or the L2 signals for ionospheric delay correction or both.

The other channelization concept uses one or more sequencing channels. A sequencing channel "listens" to a particular satellite for a period of time, making measurements on that satellite's signal before it switches to another satellite. A single channel receiver must sequence through four satellites to obtain a three-dimensional position fix. Before a first fix can be obtained, however, the receiver has

to dwell on each satellite's signal for at least 30 seconds to acquire sufficient data from the satellite's broadcast message. The time to first fix and the time between position updates can be reduced by having a pair of sequencing channels.

A variation of the sequencing channel concept is the multiplexing channel. With a multiplexing channel, a receiver sequences through the satellites at a fast rate so that all of the broadcast messages from the individual satellites are acquired essentially simultaneously. For a multiplexing receiver, the time to first fix can be 30 seconds or less, the same as for a receiver with dedicated multiple channels.

Until the early 1990s, receivers with single channels were cheaper to build than multichannel units but, because of their slowness, were restricted to low-speed applications. Most modern civil GPS receivers have 8–12 dedicated channels. Some have 24 or even 40 channels for multisystem and dual-frequency processing. Receivers with dedicated channels have greater sensitivity, because they can make measurements on the signals more often.

Microprocessor and Memory. A microprocessor controls a GPS receiver's operation. As these devices have become more and more powerful, they have taken on more of the signal processing tasks in the receiver. The microprocessor's software, that is, the instructions for running the receiver, is embedded in memory either within the microprocessor itself or in auxiliary integrated circuits within the receiver.

The microprocessor works with digital samples of pseudorange and carrier phase, acquired as a result of analog-to-digital conversion at some point in the signal flow through the receiver and the cross-correlation process. The receiver uses these data samples to establish its position, velocity, and time. The microprocessor may also run routines to filter this raw data in order to reduce the effect of noise or to get more reliable positions and velocities when the receiver is in motion.

In addition, the microprocessor may be required to carry out computations for waypoint navigation, to convert coordinates from the standard World Geodetic System of 1984 (WGS 84) geodetic datum to a regional one, and to combine differential corrections from ground-based or satellite-based augmentation systems. It also manages the input of commands from the user, the information display, and the flow of data through its communication port, if it has one.

Power Supply. Most GPS receivers have internal DC power supplies, often in the form of rechargeable batteries. Some even use "pen-

light" batteries. The latest receivers have been designed to draw as little current as possible to extend the operating time between battery charges or replacement. The receiver may also include a small onboard lithium battery for keeping memory circuits "alive" while the receiver is not operating.

These basic building blocks have appeared in essentially all GPS receivers ever built. But the size, power requirements, and capabilities of these blocks have evolved over the past 20 years or so. Before taking a look at the functioning aspects of these blocks in a modern miniature GPS receiver, it will be instructive to look at how far we have come, which will also help us appreciate the progress of technology during the past two decades.

RECEIVER RUNDOWN

The first GPS receivers, built in the 1970s, were used for the initial testing of the GPS concept. Mostly developed under contracts with the Department of Defense (DoD), these units were prototypes for various branches of the military. For our purpose, however, we will primarily focus on the technological advances of receivers developed for the civil market, with occasional reference to military receivers.

The first commercially available GPS receiver was the STI-5010 built by Stanford Telecommunications, Inc. It was a dual-frequency, C/A- and P-code, slow-sequencing receiver. Cycling through four satellites took about five minutes, and the receiver unit alone required about 30 centimeters of rack space. External counters, also requiring rack space, made pseudorange measurements. An external computer controlled the receiver and computed positions. A variant of the STI-5010 was developed for the GPS control segment tracking stations.

The Macrometer. Researchers at the Massachusetts Institute of Technology initially introduced another early civil GPS receiver, the Macrometer V-1000, in 1982, and Litton Aero Service subsequently commercialized it. Users could transport the unit and successfully deployed it using both small vehicles and helicopters, despite its size of 58 × 56 × 64 centimeters and weight of 73 kilograms, exclusive of the 18-kilogram antenna. A far cry from a wristwatch!

These units used codeless squaring to make carrier-phase measurements, which meant they made no pseudorange measurements nor did they decode any broadcast ephemeris data. Real-time operations were thus ruled out. Furthermore, clock synchronization using the GPS signals was not possible. As a result of these limitations, users needed to employ at

least two receivers simultaneously. Plus, before being deployed, they had to be synchronized to each other as well as to Coordinated Universal Time (UTC). Auxiliary equipment permitted UTC synchronization, using time signals such as those from one of the Geostationary Operational Environmental Satellites.

The Macrometer recorded its data in non-volatile bubble memory in the receiver, and users transferred it to a small data cartridge after the recording session. Data could then be processed after the mission using ephemerides obtained from other sources. This particular receiver was known for its well-designed, although large, antenna which had exceptional phase-center stability. The Macrometer V-1000 and its successor, the dual-frequency Macrometer II, were used extensively for a number of years.

The TI 4100. Also introduced in 1982 was the first relatively compact civil GPS receiver, the Texas Instruments TI 4100, also known as the Navstar Navigator. This receiver could make both C/A- and P-code measurements along with carrier-phase measurements on both L1 and L2 frequencies. Its single hardware channel could track four satellites simultaneously through a multiplexing arrangement. The $37 \times 45 \times 21$ -centimeter receiver/processor had a handheld control and display unit and an optional dual-cassette data recorder for saving measurements for postprocessing. The unit, although portable, weighed 25 kilograms and consumed 110 watts of power (the receiver doubled as a hand warmer). Field operation required a supply of automobile batteries.

During their heyday, the TI 4100 and the Macrometer were used around the world for high-precision surveying and the establishment of geodetic networks. In fact, surveyors and geodesists were the primary GPS users while the GPS constellation consisted of only the prototype Block I satellites. The concepts of single- and double-difference observations were pioneered with these early survey-quality receivers.

Beginning around the mid-1980s, a number of companies entered the market and started producing receivers for surveying, navigation, and time transfer. Ever since, a continuous evolution of GPS receivers has taken place with receiver capabilities being enhanced while size and power consumption have been reduced.

Here Come the Handhelds. GPS receiver technology experienced a major evolution in 1988. In that year, the Collins Division of Rockwell International demonstrated a prototype of the first handheld receiver. It was about the same size as a large-size package of cigarettes and

therefore affectionately known as the “Virginia Slim” after a popular brand. Researchers designed and built the prototype receiver under contract from the DoD’s Defense Advanced Research Projects Agency (DARPA). It was a two-channel, dual-frequency, P-code unit, employing custom-designed integrated circuits based, in part, on gallium arsenide (GaAs) semiconductor technology. The use of GaAs circuitry in a GPS receiver was, and is, unusual as most receivers are based on conventional silicon technology (see the “Semiconductor Basics” sidebar).

In addition to its novel use of GaAs circuitry, the receiver featured the first hybrid analog/digital microwave monolithic inte-

grated circuit (IC) chip. Also the first all-digital receiver, the unit performed code-correlation using digital rather than analog signals. Achievement of all-digital GPS processing opened the door for developers to exploit very-large-scale integration (VLSI) in GPS receivers.

The DARPA receiver efforts sparked development of handheld receivers by other companies. Magellan introduced the first commercial handheld GPS unit in 1988, named the NAV 1000. In a $19 \times 8.9 \times 5.3$ -centimeter, 850-gram package, its single sequencing channel could track four satellites. During that year, Trimble introduced its Trim-pak. It was a three-channel sequencing

SEMICONDUCTOR BASICS

The miniaturization of the GPS receiver was made possible by the phenomenal developments in semiconductor technology during the past 20 years. But just what is a semiconductor? A semiconductor is a material such as silicon (Si) or germanium (Ge) in which the electrical conductivity lies between that of conductors and insulators. However, the resistivity of pure silicon, for example, is so high (about 10^{11} times that of copper) that it is virtually an insulator and therefore not much use in electronic circuits. But by adding minute amounts of specific “impurity” or replacement atoms, a process called *doping*, the resistivity can be reduced by a factor of 10^6 or more. Replacement atoms include antimony, phosphorus, arsenic, and aluminum. The doped semiconductor conducts current either by negative or positive carriers depending on the dopant. Actually, the positive carrier is virtual. The electron still carries the charge, but it is the physical absence of the electron that moves, and this virtual carrier is called a *hole*.

By combining semiconducting material that has an abundance of electrons (negative or n-type) with material that has an abundance of holes (positive or p-type), electronic circuit devices can be created in which the current flow through the device can be externally controlled, operating as a rectifier, a basic switch, or an amplifier. Examples of semiconductor devices include diodes and transistors. To build a complete electronic circuit out of these basic components may require just one semiconductor, such as a “minimalist” radio using only a single diode (a “crystal set”), to many millions as found in computers.

To significantly reduce the parts count necessary to build complex pieces of electronic equipment, such as GPS receivers, transistors and other electronic components, including capacitors and resistors, are crafted into a single semiconducting chip, forming an integrated circuit. A chip may contain just a few transistors or more than a million. The Power PC 620 microprocessor chip, for example, incorporates almost seven million transistors, along with many other electronic components. The number of transistors that semiconductor manufacturers can put on a chip doubles about every 18 months.

Some integrated circuits use simple bipolar transistors. *Bipolar* refers to the type of transistor construction that has either two p-regions, one on either side of an n-region (a pnp transistor) or two n-regions and one p-region (an npn transistor). This transistor “sandwich” is called a junction transistor. Most GPS receiver front-end chips use bipolar silicon technology.

However, the transistors in some integrated circuits are complementary metal oxide semiconductors (CMOS). Whereas bipolar devices use junction transistors, CMOS devices use a particular kind of field effect transistor, the MOSFET. Similar to bipolar transistors, MOSFETs have p- and n-type regions, but the central region is made up of a substrate of silicon semiconductor material on top of which is an insulating layer of silicon dioxide (glass), and on top of the oxide layer is a metal “gate.”

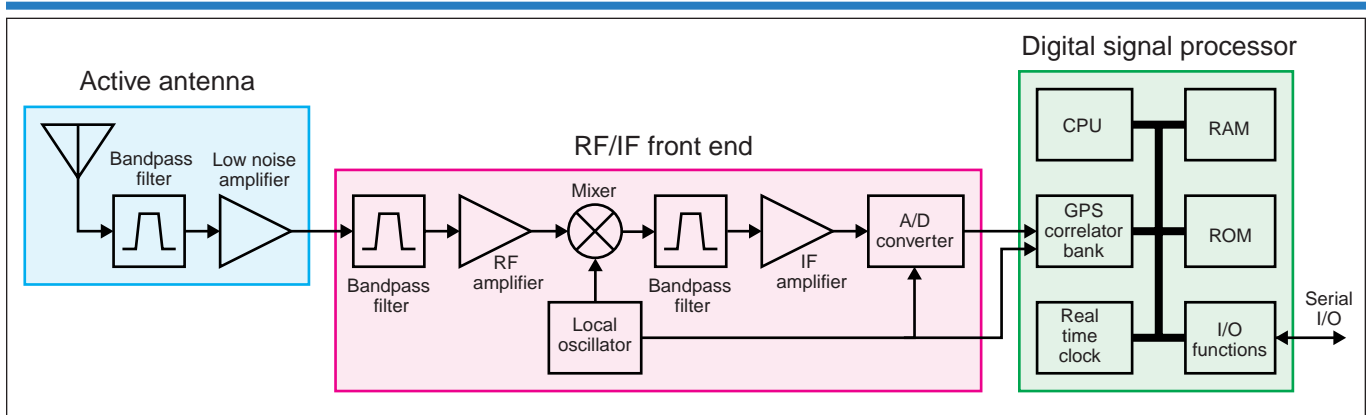

Figure 1. A GPS receiver can be constructed from just two major integrated circuits: an RF/IF front end (“radio chip”) and a digital signal processor.

When a voltage is applied to that metal gate, an electric field is established that penetrates through the insulator into the substrate, allowing current to flow in a channel along the top of the substrate. CMOS combines both p- and n- channel devices in the same substrate to achieve high noise immunity and low power consumption — a negligible amount during standby. This accounts for the widespread use of CMOS in battery-operated equipment. Furthermore, by 1996, individual MOSFETs could be made extremely small, less than 500 nanometers in length (which is approximately the wavelength of yellow light), allowing large numbers of them to be packed into a single integrated circuit.

Silicon is not the only semiconductor used to make ICs for GPS receivers. ICs made from gallium arsenide (GaAs) and silicon germanium (SiGe) are also available. Gallium arsenide has greater electron mobility and a correspondingly higher maximum operating frequency than typical silicon devices. Its low-noise characteristics make it an appropriate choice for discrete low-noise amplifiers and for mixers operating at high frequencies. The key advantages of silicon-germanium technology are high-frequency performance at lower power consumption and extremely low phase noise with apparently lower processing cost compared to GaAs-based devices.

receiver and could track eight satellites. Although slightly larger than the NAV 1000, measuring $19.8 \times 6.4 \times 22.4$ centimeters and weighing 1.5 kilograms, it could still be held in one hand. Coalition forces in the 1991 Gulf War widely used both military and civil versions of the NAV 1000 and the Trimpak.

The next significant development in the miniaturization of the GPS receiver occurred in 1993. In that year, the Mayo Foundation and Motorola demonstrated the first GPS multi-chip module (MCM) receiver. MCM construction is similar to conventional printed circuit boards (PCBs) but uses smaller physical geometries and a special substrate, the material on which a circuit is constructed or fabricated. They took an existing six-channel GPS receiver design that used single-chip packaging and conventional PCB technology and miniaturized it to a double-sided MCM measuring just $3.5 \times 3.6 \times 1.0$ centimeters fully assembled.

The MCM contained both surface-mount components and bare die (chip circuitry) on both sides of an eight-layer substrate. The unit dissipated about 1.3 watts. In combining the very low-level analog RF signals with high-level digital processing of these signals on the same substrate, the developers had to take special care to prevent the digital signals from interfering with the RF signals by carefully placing parts.

Several companies now offer small handheld GPS receivers built with a small number of integrated circuits. Some of these ICs are generic ones used in different kinds of electronic devices, but some of them have been specially developed for GPS use. These application-specific integrated circuits (ASICs) have significantly reduced the number of components needed to build GPS receivers and hence their size and power consumption. In fact, the chip manufacturers offer the ASICs

to other manufacturers for building standalone GPS receivers or for embedding a receiver into another product.

THE WORKINGS OF A CHIPSET

It is common now for the RF and IF functions of a GPS receiver to be combined on a single ASIC, supplying the IF signal to another ASIC: a digital signal processing chip, which typically includes an eight- or 12-channel correlator array. Although a GPS receiver’s microprocessor may be a separate IC, ASICs have been developed that combine the correlators and support functions (such as serial ports) together with the microprocessor in a single chip. Today, the chip can even include onboard read-only memory (ROM) and random-access memory (RAM), making a complete two-chip GPS receiver.

Figure 1 presents a block diagram of a GPS receiver built using only two major integrated circuits. The signal from the antenna feeds into the RF/IF front-end chip. Depending on the antenna cabling’s length and front-end input signal level requirements, an active antenna (with a preamplifier) rather than a passive antenna may be required. In the RF/IF chip, the signal is first bandpass filtered and amplified before being mixed with the signal from the local oscillator to generate the IF. The bandpass filtering helps to protect the GPS signal from interference, for example, from cellular phone signals.

Some chip designs have external local oscillators that supply timing signals to both the RF/IF chip and the signal processing chip. Some designs use more than one IF stage, reducing the intermediate frequency in steps with filtering and amplification at each step. The filters and the crystal for the oscillator are typically outside the chip package. Some front-end designs use larger encapsulated-module packaging and include the filters and

FURTHER READING

For the first paper to discuss the possibility and potential for a GPS "wrist locator," see

■ "The Future of Geodetic Networks," by P. Vaniček, D.E. Wells, A. Chrzanowski, A.C. Hamilton, R.B. Langley, J.D. McLaughlin, and B.G. Nickerson, published in the *Proceedings of the International Association of Geodesy Symposia*, International Union of Geodesy and Geophysics, XVIII General Assembly, Hamburg, Germany, August 15–27, 1983, Vol. 2, pp. 372–379.

For more details on some of the early GPS receivers, see

■ *Guide to GPS Positioning*, edited by D. Wells, originally published in 1986 by Canadian GPS Associates and recently reprinted by the University of New Brunswick, Fredericton, Canada, as Department of Geodesy and Geomatics Engineering Lecture Note No. 58.

For further details about modern GPS receiver mechanization, see

■ "GPS Receivers," by A.J. Van Dierendonck, Chapter 8 in *Global Positioning System: Theory and Applications*, Vol. 1, edited by B.W. Parkinson and J.J. Spilker Jr., American Institute of Aeronautics and Astronautics, Inc., Washington D.C. 1996.

■ "GPS Receiver Architectures and Measurements," by M.S. Braasch and A.J. Van Dierendonck in *Proceedings of the IEEE*, Vol. 87, No. 1, pp. 48–64, 1999.

For a review of the past, present, and future of semiconductor technology, see

■ *The Solid-state Century*, Scientific American Special Issue, Vol. 8, No. 1, 1997.

even the local oscillator crystal.

Typically, the RF/IF chip includes an onboard analog-to-digital converter that samples the final IF signal with one- or two-bit quantization before passing it on to the signal processing chip. A synchronizing clock signal is also passed. Once the signal is sampled, all further signal processing is done digitally.

Processing the Digital Signal. The digital signal processing (DSP) chip incorporates a central processing unit (CPU) microprocessor, which is the workhorse of a GPS receiver. Some DSP designs do all of the signal processing in a powerful CPU, but it is more common to use hardware correlators onboard the chip. Typically an eight- or 12-channel bank of correlators is provided. The DSP chip may include onboard ROM and RAM, or the memory may be provided by separate ICs. Some GPS chips run their software from flash memory that can be upgraded by the user. The DSP chip would also include interface and power-management circuitry.

The power for both the RF/IF and DSP chips is usually provided by a 5- or 3.3-volt DC supply. Power consumption depends on chip usage, but typically the RF/IF chip consumes 100–200 milliwatts and the DSP chip, 300–500 milliwatts.

WRIST-MOUNT GPS

Multichip modules that implement multiple unpackaged chips on a single substrate have

enabled manufacturers to complete receivers as small as $30 \times 30 \times 6$ millimeters, small enough to put in a wristwatch. In fact, researchers at the University of New Brunswick (UNB) first predicted exactly that — a "wrist locator" — in a paper presented at the International Union of Geodesy and Geophysics quadrennial meeting in Hamburg, Germany, in 1983. In that paper, they said "With the miniaturization and cost reduction being experienced continually, it is surely safe to postulate the limit of this evolution: a cheap 'wrist locator' giving instantaneous positions to an accuracy of 1 [millimeter]." Elsewhere in the paper, they suggested a price for this technological wonder of \$10, and that it would be available sometime in the twenty-first century.

Costing about \$400 and giving Standard Positioning Service accuracies, the first "wrist locator" came on the market last year — before the twenty-first century began. While the UNB researchers may have been a bit overly optimistic in the capabilities and cost of the "wrist locator," the basic prediction came true earlier than expected. And there's room for further development.

ANYTHING BUT DISAPPEARING

The demand for smaller, cheaper, power-thrifty GPS receivers will continue. Receiver designers have already reduced the number of ICs needed to just two. Is a one-chip GPS receiver possible, and how small can the

receiver be made? A complete GPS system on a single chip should be possible, but cross-talk between the digital signals and the weak analog signals on the chip will need to be addressed. New chip packaging technologies also will help in reducing the size. Integration of the receiver into a wearable computer built into clothes may even be possible one day.

While these technologies may seem far fetched, scientists are already working on such developments. A limiting factor could be the size of the receiver's antenna. The smaller the antenna, the less sensitive it is. But GPS antennas smaller than 2.5×2.5 centimeters are available today. The GPS signals are fairly weak, but with more sensitive front ends and more sophisticated signal processing, even smaller antennas should be possible.

Researchers have built a solid-state molecular switch that is electronically configurable. This work could lead to the development of chemically-assembled ICs with molecular-sized devices that would need a minuscule amount of power. Thus, as each of these elements improve, so too do the opportunities for new, even smaller GPS receivers.

In *The Incredible Shrinking Man*, Grant Williams gets smaller and smaller until he disappears in a puff of wind. The GPS receiver will not get that small, but it could conceivably become small enough to be implanted under the skin and, coupled with other sensors and a transmitter, used to track people and their vital health signs. As hard as it may be to believe, at least one company is already working on a prototype for just such a device. ■

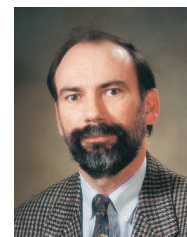

"Innovation" is a regular column featuring discussions about recent advances in GPS technology and its applications as well as the fundamentals of GPS positioning. The column is coordinated by

Richard Langley of the Department of Geodesy and Geomatics Engineering at the University of New Brunswick, who appreciates receiving your comments as well as topic suggestions for future columns. To contact him, see the "Columnists" section on page 4 of this issue.